

- ( ) Preliminary Specifications
- ( V ) Final Specifications

<b>Module</b>	7 Inch Color TFT-LCD
<b>Model Name</b>	B070ATN01.3

<p><b>Customer</b></p> <p>_____</p>	<p><b>Date</b></p> <p>_____</p>
<p><b>Checked &amp; Approved by</b></p> <p>_____</p>	

<p><b>Approved by</b></p> <p><u>Grace Hung</u></p>	<p><b>Date</b></p> <p><u>2019/05/06</u></p>
<p><b>Prepared by</b></p> <p><u>Kevin Tseng</u></p>	
<p><u>2019/05/06</u></p>	
<p>General Display Business Division / AU Optronics corporation</p>	

# Contents

<b>1. Operating Precautions</b> .....	<b>4</b>
<b>2. General Description</b> .....	<b>5</b>
2.1 Display Characteristics .....	5
2.2 Optical Characteristics .....	6
<b>3. Functional Block Diagram</b> .....	<b>9</b>
<b>4. Absolute Maximum Ratings</b> .....	<b>10</b>
4.1 Absolute Ratings of TFT LCD Module.....	10
4.2 Absolute Ratings of Environment .....	10
<b>5. Electrical Characteristics</b> .....	<b>11</b>
5.1.1 Power Specification.....	11
5.1.2 Signal Electrical Characteristics .....	13
5.2 Backlight Driving Condition .....	14
<b>6. Signal Characteristic</b> .....	<b>15</b>
6.1 Pixel Format Image .....	15
6.2 Scanning Direction .....	15
6.3 The Input Data Format .....	16
6.4 Signal Description .....	17
6.5 Interface Timing.....	19
6.6 Power ON/OFF Sequence .....	20
<b>7. Reliability Test Criteria</b> .....	<b>21</b>
<b>8. Mechanical Characteristics</b> .....	<b>22</b>
8.1 LCM Outline Dimension .....	22
<b>9. Label and Packaging</b> .....	<b>23</b>
9.1 Shipping Label (on the rear side of TFT-LCD display) .....	23
9.2 Carton Package.....	24
<b>10 Safety</b> .....	<b>25</b>
10.1 Sharp Edge Requirements .....	25
10.2 Materials .....	25
10.3 Capacitors .....	25
10.4 National Test Lab Requirement .....	25

### Record of Revision

Version	Date	Page	Old description	New Description							
1.0	2018/10/02	All	First draft specification								
1.1	2018/10/24	21		Add Carton package test <table border="1"> <tr> <td>Carton package vibration test:</td> <td>Condition &amp; Length : Random 1.5G 10~200Hz , X, Y, Z directions,30min/direction-</td> </tr> <tr> <td>Carton package drop test:</td> <td>Height 61cm; 1 corner, 3 edges, 6 flats-</td> </tr> </table>	Carton package vibration test:	Condition & Length : Random 1.5G 10~200Hz , X, Y, Z directions,30min/direction-	Carton package drop test:	Height 61cm; 1 corner, 3 edges, 6 flats-			
Carton package vibration test:	Condition & Length : Random 1.5G 10~200Hz , X, Y, Z directions,30min/direction-										
Carton package drop test:	Height 61cm; 1 corner, 3 edges, 6 flats-										
1.2	2019/04/08	11		Add Vcom data <table border="1"> <tr> <td>Vcom:</td> <td>Com Voltage:</td> <td>2.7:</td> <td>2.9:</td> <td>3.1:</td> <td>Vj:</td> <td>ρ</td> </tr> </table>	Vcom:	Com Voltage:	2.7:	2.9:	3.1:	Vj:	ρ
		Vcom:	Com Voltage:	2.7:	2.9:	3.1:	Vj:	ρ			
23		Add label SN definition 									
1.2	2019/04/08	22		Add dimension data in rear view.							
1.2	2019/04/08	7	$\delta_{ws} = \dots \frac{\text{Maximum Brightness of five points}}{\text{Minimum Brightness of five points}}$	$\delta_{ws} = \dots \frac{\text{Minimum Brightness of five points}}{\text{Maximum Brightness of five points}}$							
1.3	2019/05/06	9	Vcom= 3.0 V	Vcom= 2.9 V							
1.3	2019/05/06	11	Note 2 : Measure Condition, Tr = TBD (ms), I = TBD (mA)	Note 2 : Measure Condition, Tr = 0.5 (ms), I = 200 (mA)							

## 1. Operating Precautions

- 1) Since front polarizer is easily damaged, please be cautious and not to scratch it.
- 2) Be sure to turn off power supply when inserting or disconnecting from input connector.
- 3) Wipe off water drop immediately. Long contact with water may cause discoloration or spots.
- 4) When the panel surface is soiled, wipe it with absorbent cotton or soft cloth.
- 5) Since the panel is made of glass, it may be broken or cracked if dropped or bumped on hard surface.
- 6) To avoid ESD (Electro Static Discharge) damage, be sure to ground yourself before handling TFT-LCD Module.
- 7) Do not open nor modify the module assembly.
- 8) Do not press the reflector sheet at the back of the module to any direction.
- 9) In case if a module has to be put back into the packing container slot after it was taken out from the container, do not press the center of the LED light bar edge. Instead, press at the far ends of the LED light bar edge softly. Otherwise the TFT Module may be damaged.
- 10) At the insertion or removal of the Signal Interface Connector, be sure not to rotate nor tilt the Interface Connector of the TFT Module.
- 11) TFT-LCD Module is not allowed to be twisted & bent even force is added on module in a very short time. Please design your display product well to avoid external force applying to module by end-user directly.
- 12) Small amount of materials having no flammability grade is used in the LCD module. The LCD module should be supplied by power complied with requirements of Limited Power Source (IEC60950 or UL1950), or be applied exemption.
- 13) Severe temperature condition may result in different luminance, response time and lamp ignition voltage.
- 14) Continuous operating TFT-LCD display under low temperature environment may accelerate lamp exhaustion and reduce luminance dramatically.
- 15) The data on this specification sheet is applicable when LCD module is placed in landscape position.
- 16) Continuous displaying fixed pattern may induce image sticking. It's recommended to use screen saver or shuffle content periodically if fixed pattern is displayed on the screen.

## 2. General Description

This specification applies to the Color Active Matrix Liquid Crystal Display B070ATN01.3 composed of a TFT-LCD display. This mode is composed with a TFT-LCD panel, driver ICs, an FPC and a backlight unit. The screen format is intended to support the WSVGA (1024(H) x 600(V)) screen and 262K (6-bits)& 16.7M (8-bits) colors by digital RGB interface.

### 2.1 Display Characteristics

The following items are characteristics summary on the table under 25 °C condition:

Items	Unit	Specifications
Screen Diagonal	[inch]	7"
Active Area	[mm]	153.6(H) × 90.0(V)
Resolution		1024 × 3(RGB) × 600
Pixel Pitch	[mm]	0.15(W) × 0.15(H)
Pixel Arrangement		R. G. B. Vertical Stripe
Display Mode		Normally White
Nominal Input Voltage VDD	[Volt]	3.3 (typ.)
Power Consumption	[Watt]	Logic power: 0.82 (Max.) BLU power: 0.93 (Max.)
Weight	[Grams]	110 (Max.)
Physical Size (Typical)	[mm]	167.25 x 104.65mm
Thickness	[mm]	2.9 (Max)
Electrical Interface (Digital/LVDS/MIP/DP)		LVDS
Surface Treatment		Anti-Glare, Hardness 3H, Reflection 4.3%
Support Color		262K/16.7M
Temperature Range Operating Storage (Non-Operating)	[°C] [°C]	-10 to +60 -30 to +70
RoHS Compliance		Yes

## 2.2 Optical Characteristics

The optical characteristics are measured under stable conditions at 25 °C (Room Temperature):

Item	Unit	Conditions	Min.	Typ.	Max.	Note
White Luminance	[cd/m <sup>2</sup> ]	ILED= 20mA per string (center points)	300	350	-	1,2
Uniformity	%	5 points	70	75	-	3,
Contrast Ratio			500	700	-	4
Response Time	[msec]	Rising	-	-	-	5
	[msec]	Falling	-	-	-	
	[msec]	Rising + Falling	-	16	25	
Viewing Angle	[degree]	Horizontal (Right)	65	75	-	6
	[degree]	CR >= 10 (Left)	65	75	-	
	[degree]	Vertical (Upper)	50	70	-	
Color / Chromaticity Coordinates (CIE 1931)		Red x	0.535	0.585	0.635	
		Red y	0.285	0.335	0.385	
		Green x	0.280	0.330	0.380	
		Green y	0.535	0.585	0.635	
		Blue x	0.105	0.155	0.205	
		Blue y	0.070	0.120	0.170	
		White x	0.263	0.313	0.363	
		White y	0.279	0.329	0.379	
Color Gamut	%		-	50	-	

### Note 1: Measurement method:

Equipment Pattern Generator, Power Supply, Digital Voltmeter, Luminance meter (SR\_3 or equivalent)

B070ATN01.3 rev 1.3

Aperture 1° with 50cm viewing distance  
 Test Point Center 5 points (See note 2)  
 Environment < 1 lux

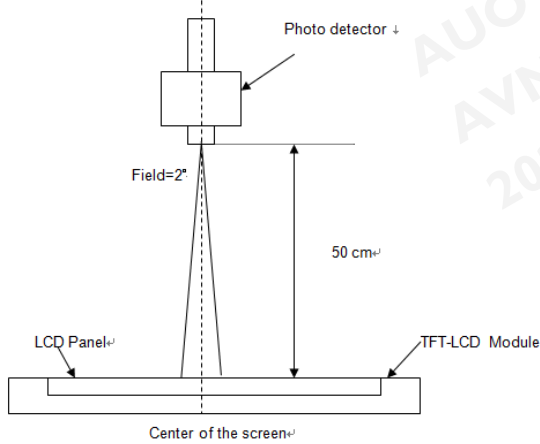

**Note 2: Definition of 5 points position (Ref: Active area):**

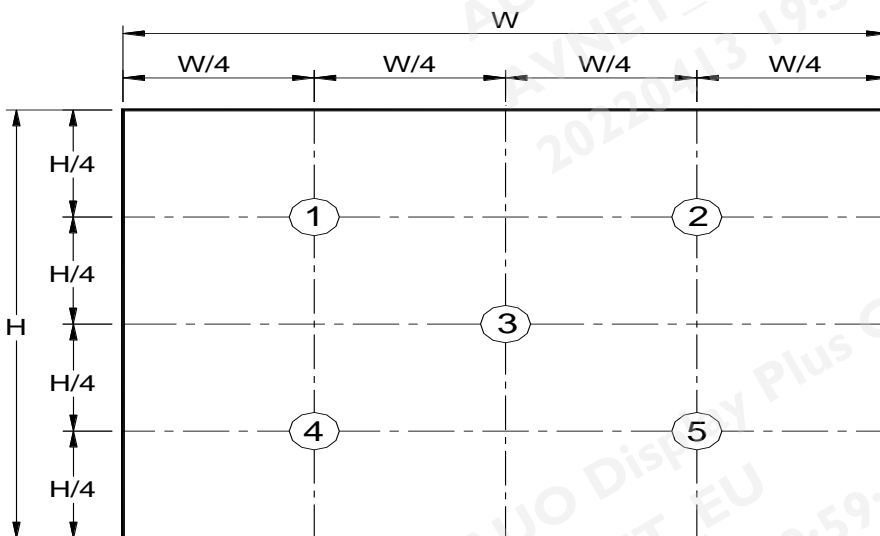

**Note 3: The luminance uniformity of 5 is defined as minimum luminance divided by the maximum luminance values the:**

$$\delta_{w5} = \frac{\text{Minimum Brightness of five points}}{\text{Maximum Brightness of five points}}$$

**Note 4: Definition of contrast ratio (CR):**

$$\text{Contrast ratio (CR)} = \frac{\text{Brightness on the "White" state}}{\text{Brightness on the "Black" state}}$$

**Note 5: Definition of response time:**

The output signals of photo detector are measured when the input signals are changed from "White" to "Black" (rising time) and from "Black" to "White" (falling time), respectively. The response time interval is between 10% and 90% of amplitudes. Please refer to the figure as below.

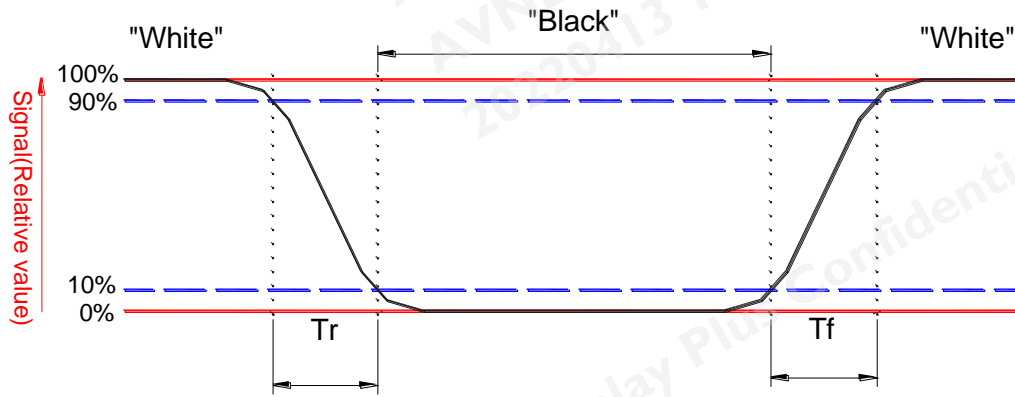

**Note 6: Definition of viewing angle:**

Viewing angle is the measurement of contrast ratio  $\geq 10$ , at the screen center, over a 180° horizontal and 180° vertical range (off-normal viewing angles). The 180° viewing angle range is broken down as below: 90° ( $\theta$ ) horizontal left and right, and 90° ( $\Phi$ ) vertical high (up) and low (down). The measurement direction is typically perpendicular to the display surface with the screen rotated to its center to develop the desired measurement viewing angle.

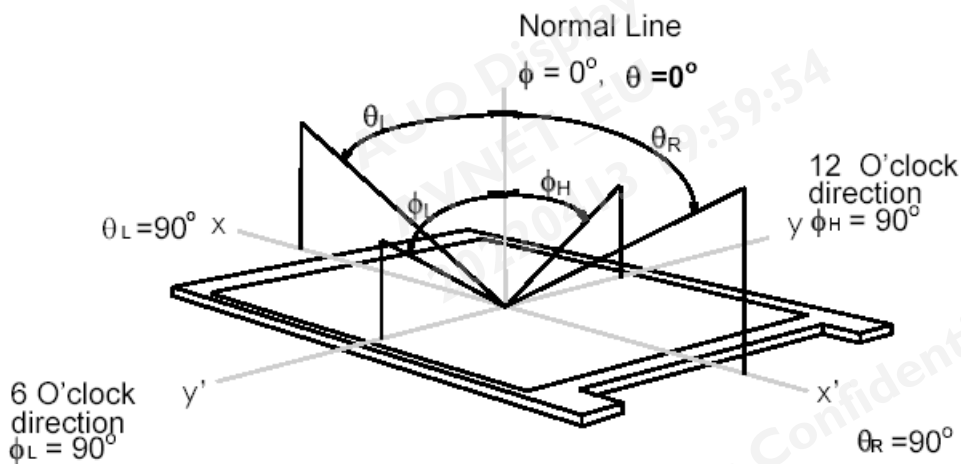



### 3. Functional Block Diagram

The following diagram shows the functional block of the 7 inch color TFT/LCD module:

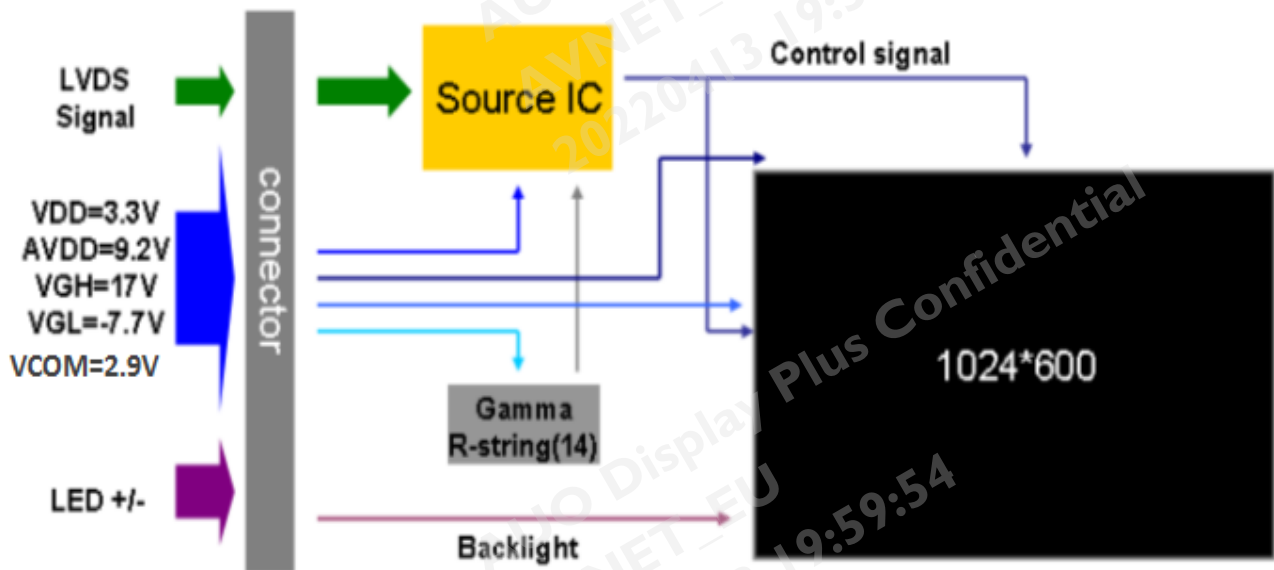

## 4. Absolute Maximum Ratings

### 4.1 Absolute Ratings of TFT LCD Module

Items	Symbol	Values		Unit	Condition
		Min.	Max.		
Logic/LCD Drive Voltage	VDD	-0.5	+4	[Volt]	Note 1,2

Note 1: Functional operation should be restricted under ambient temperature. (25°C).

Note 2: Maximum ratings are those values beyond which damages to the device may occur. Functional operation should be restricted to the limits in the electrical characteristics chapter.

### 4.2 Absolute Ratings of Environment

Item	Symbol	Min	Max	Unit
Operating Temperature	TOP	-10	60	[°C]
Operation Humidity	HOP	0	90	[%RH]
Storage Temperature	TST	-30	70	[°C]
Storage Humidity	HST	5	90	[%RH]

Note 1: At Ta (25°C )

Note 2: Permanent damage to the device may occur if exceed maximum values

Note 3: LED specification refer to section 5.2

Note 4: For quality performance, please refer to AUO IIS (Incoming Inspection Standard).

## 5. Electrical Characteristics

### 5.1.1 Power Specification

Input power specifications are as follows;

The power specification are measured under 25°C and frame frequency under 60Hz

Symble	Parameter	Min	Typ	Max	Units	Note
VDD	Digital Voltage	3.0	3.3	3.6	[Volt]	
PVDD	Digital Power	-	-	660	[mWatt]	Note 1
Idc	Digital Current	-	170	200	[mA]	Note 1
AVDD	Analog Voltage	9.02	9.2	9.38	[Volt]	
PAVDD	Analog Power			150	[mWatt]	
Iac	Analog Current		13.6	16.3	[mA]	
VGH	LCD ON		0.34		[mA]	
		16.5	17	17.5	[V]	
VGL	LCD OFF		0.37		[mA]	
		-8.2	-7.7	-7.2	[V]	
Vcom	Com Voltage	2.7	2.9	3.1	[V]	
IRush	Inrush Current	-	-	2	[A]	Note 2&3
VDDrp	Allowable Logic/LCD Drive Ripple Voltage	-	-	100	[mV] p-p	

Note 1 : Maximum Measurement Condition : Black Pattern at 3.3V driving voltage. ( $P_{max}=V_{3.3} \times I_{black}$ )

Note 2 : Measure Condition,  $T_r = 0.5$  (ms),  $I = 200$  (mA)

Note 3 : Max 500 mV voltage drop is acceptable after VDD input (3.0V~3.6V) 0~200ms

Parameter	Min	Typ	Max	Units	Note
Input low voltage level	0	-	0.3*VDD	[Volt]	For digital I/O
Input high voltage level	0.7*VDD	-	VDD	[Volt]	For digital I/O

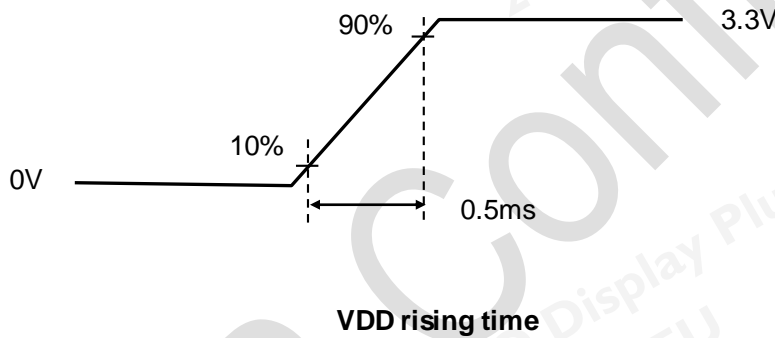
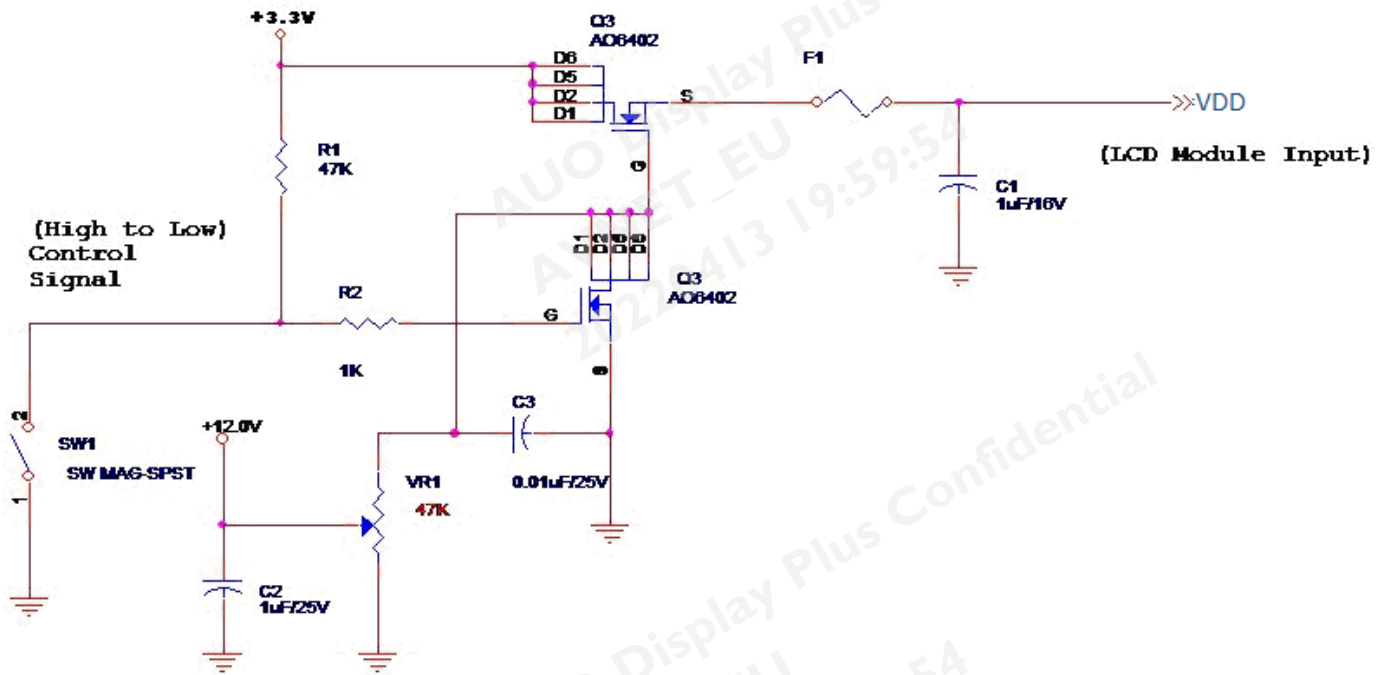

### 5.1.2 Signal Electrical Characteristics

The following items are measured under stable condition.

Parameter	Condition	Min	Max	Unit
$V_{th}$	Differential Input High Threshold ( $V_{cm}=+1.2V$ )		0.1	[V]
$V_{tl}$	Differential Input Low Threshold ( $V_{cm}=+1.2V$ )	-0.1	-	[V]
$V_{se}$	Input voltage range (singled-end)	0	2.4	[V]
$V_{cm}$	Differential Input Common Mode Voltage	1.125	1.375	[V]
$V_{ID}$	Differential Input Voltage	0.1	0.6	[V]

Note: LVDS Signal Waveform

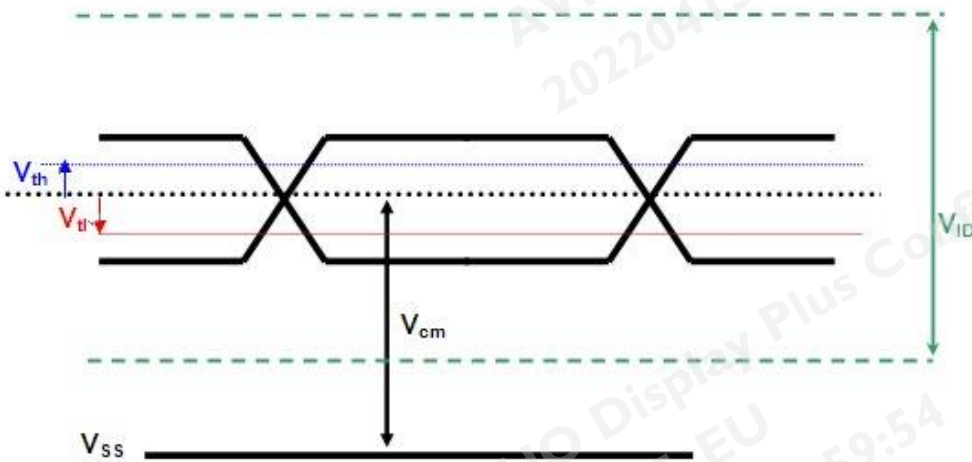

## 5.2 Backlight Driving Condition

### 5.2.1 Parameter guideline for LED

Parameter	Symbol	Min	Typ	Max	Units	Condition
Backlight Power Consumption	PLED	-	0.855	0.93	[Watt]	(Ta=25°C), Note 1
LED Life-Time	N/A	20,000	30,000	-	Hour	(Ta=25°C), Note 2 I <sub>F</sub> =20 mA
Input Voltage	V <sub>Light-bar</sub>	-	8.55	9.3	V	I <sub>F</sub> =20mA per String
Input current	I <sub>Light-bar</sub>	-	100	-	mA	I <sub>F</sub> =20mA per String
Reverse Current Ignore	I <sub>R</sub>	-	-	-	uA	V <sub>R</sub> = $\Delta$ V

**Note 1:** Calculator value for reference  $P_{LED} = V_F$  (Normal Distribution) \*  $I_F$  (Normal Distribution), and PLED exclude driving circuit loss.

**Note 2:** The LED life-time define as the estimated time to 50% degradation of initial luminous.

**Note 3:** LED combination: 3 series 5 parallel.

## 6. Signal Characteristic

### 6.1 Pixel Format Image

Following figure shows the relationship between input signal and LCD pixel format.

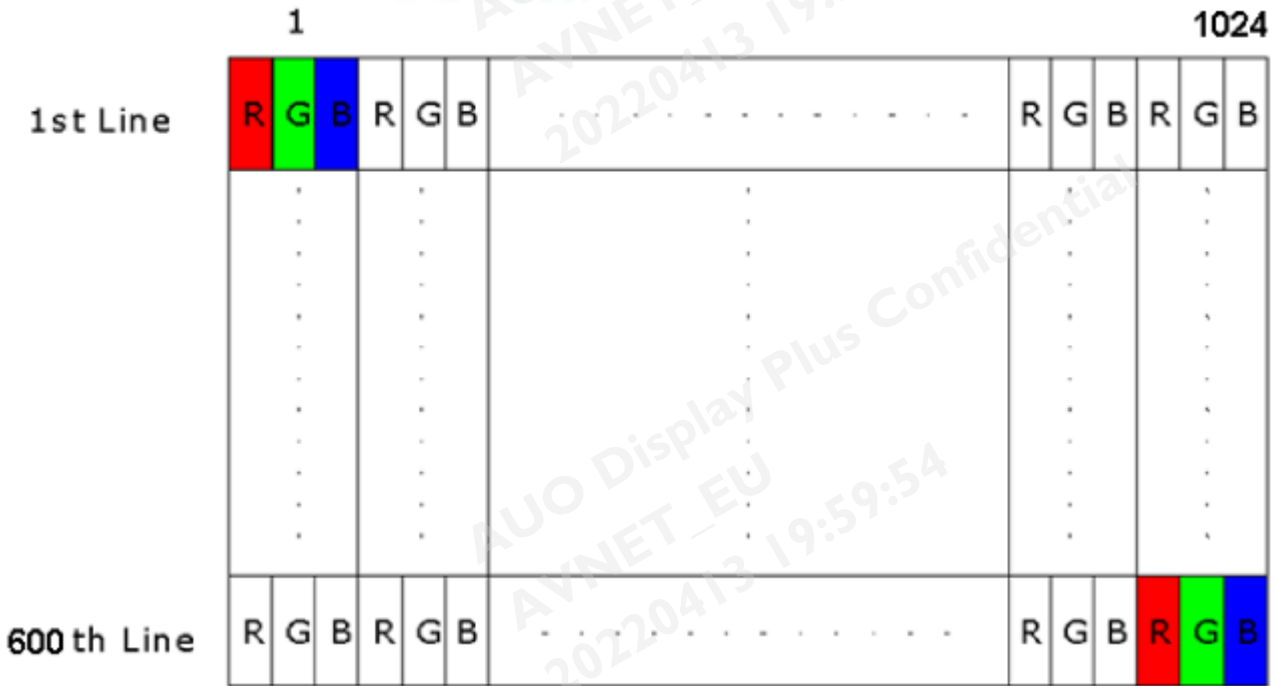

### 6.2 Scanning Direction

The following figures show the image seen from the front view. The arrow indicates the direction of scan



SHLR = High; UPDN = Low



SHLR = Low; UPDN = Low

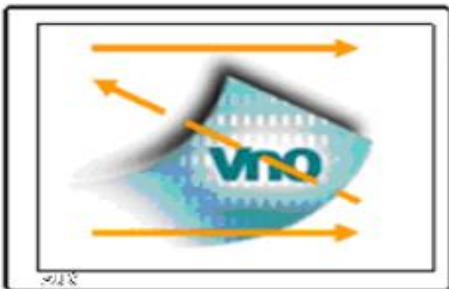

SHLR = High; UPDN = High



SHLR = Low; UPDN = High

## 6.3 The Input Data Format

### SEL68 = "High" for 6 bits LVDS Input



### SEL68 = "Low" or "NC" for 8 bits LVDS Input

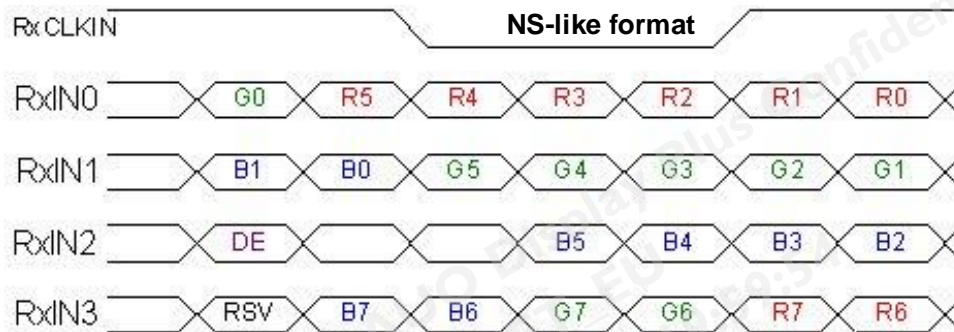

**Note1:** Please follow PSWG.

**Note2:** R/G/B data 7:MSB, R/G/B data 0:LSB

Signal Name	Description	Remark
R7	Red Data 7	Red-pixel Data  For 8Bits LVDS input MSB: R7 ; LSB: R0  For 6Bits LVDS input MSB: R5 ; LSB: R0
R6	Red Data 6	
R5	Red Data 5	
R4	Red Data 4	
R3	Red Data 3	
R2	Red Data 2	
R1	Red Data 1	
R0	Red Data 0	
G7	Green Data 7	Green-pixel Data  For 8Bits LVDS input MSB: G7 ; LSB: G0  For 6Bits LVDS input MSB: G5 ; LSB: G0
G6	Green Data 6	
G5	Green Data 5	
G4	Green Data 4	
G3	Green Data 3	
G2	Green Data 2	
G1	Green Data 1	
G0	Green Data 0	
B7	Blue Data 7	Blue-pixel Data  For 8Bits LVDS input MSB: B7 ; LSB: B0  For 6Bits LVDS input MSB: B5 ; LSB: B0
B6	Blue Data 6	
B5	Blue Data 5	
B4	Blue Data 4	
B3	Blue Data 3	
B2	Blue Data 2	
B1	Blue Data 1	
B0	Blue Data 0	
RxCLKIN	LVDS Data Clock	
DE	Data Enable Signal	When the signal is high, the pixel data shall be valid to be displayed.

Note: Output signals from any system shall be low or Hi-Z state when VDD is off.



## 6.4 Signal Description

This product displays 16.7M colors in terms of the 256 grey levels on RGB respectively.

### 6.4.1 Pin Assignment

No.	Pin Name	Description	Remarks
1	Vcom	Com Voltage	
2	VDD	Power Voltage for digital circuit	
3	VDD	Power Voltage for digital circuit	
4	NC	No connection	
5	Reset	Global reset pin	Active Low to enter ResetState
6	STBYB	Standby mode, Normally pulled high	STBYB="1", Normally operation, STBYB="0", Timing controller, all output are High-Z
7	GND	Ground	
8	RXIN0-	- LVDS differential data input	
9	RXIN0+	+LVDS differential data input	
10	GND	Ground	
11	RXIN1-	-LVDS differential data input	
12	RXIN1+	+LVDS differential data input	
13	GND	Ground	
14	RXIN2-	-LVDS differential data input	
15	RXIN2+	+LVDS differential data input	
16	GND	Ground	
17	RXCLKIN-	+LVDS differential clock input	
18	RXCLKIN+	+LVDS differential clock input	
19	GND	Ground	
20	RXIN3-	-LVDS differential data input	
21	RXIN3+	+LVDS differential data input	
22	GND	Ground	
23	NC	No connection	
24	NC	No connection	
25	GND	Ground	

No.	Pin Name	Description	Remarks
26	NC	No connection	
27	NC	No connection	
28	SELB	6/8 bit select H : 6 bit L : 8 bit	
29	AVDD	Analog Power	
30	GND	Ground	
31	LED-	LED Cathode	
32	LED-	LED Cathode	
33	L/R	Horizontal inversion	L/R=1, from left to right; L/R=0, from right to left
34	U/D	Vertical inversion	U/D=0, from up to down; U/D=1, from down to up
35	VGL	Gate OFF Voltage	
36	NC	No connection	
37	NC	No connection	
38	VGH	Gate ON Voltage	
39	LED+	LED Anode	
40	LED+	LED Anode	

## 6.5 Interface Timing

### 6.5.1 Timing Characteristics

Parameter	Symbol	Min.	Typ.	Max.	Unit	
Frame Rate	-	-	60	-	Hz	
Clock frequency	1/ T <sub>clock</sub>	40.8	51.2	67.2	MHz	
Input data skew margin	-	-	-	670	ps	
Clock high time	-	-	13.6	-	ns	
Clock low time	-	-	10.2	-	ns	
Data Setup time	-	1	-	-	ns	
Data Hold time	-	1	-	-	ns	
Horizontal Section	Period	T <sub>H</sub>	1114	1344	1400	T <sub>clock</sub>
	Active	T <sub>HD</sub>	1024			
	Blanking	T <sub>HB</sub>	90	320	376	
Vertical Section	Period	T <sub>V</sub>	610	635	800	T <sub>Line</sub>
	Active	T <sub>VD</sub>	600			
	Blanking	T <sub>VB</sub>	10	35	200	

**Note1:** DE mode only

**Note2:** Support customer LVDS

**Note3:** Input data skew margin max value test condition at 42.75Mhz and 100mV

### 6.5.2 Input Timing Diagram

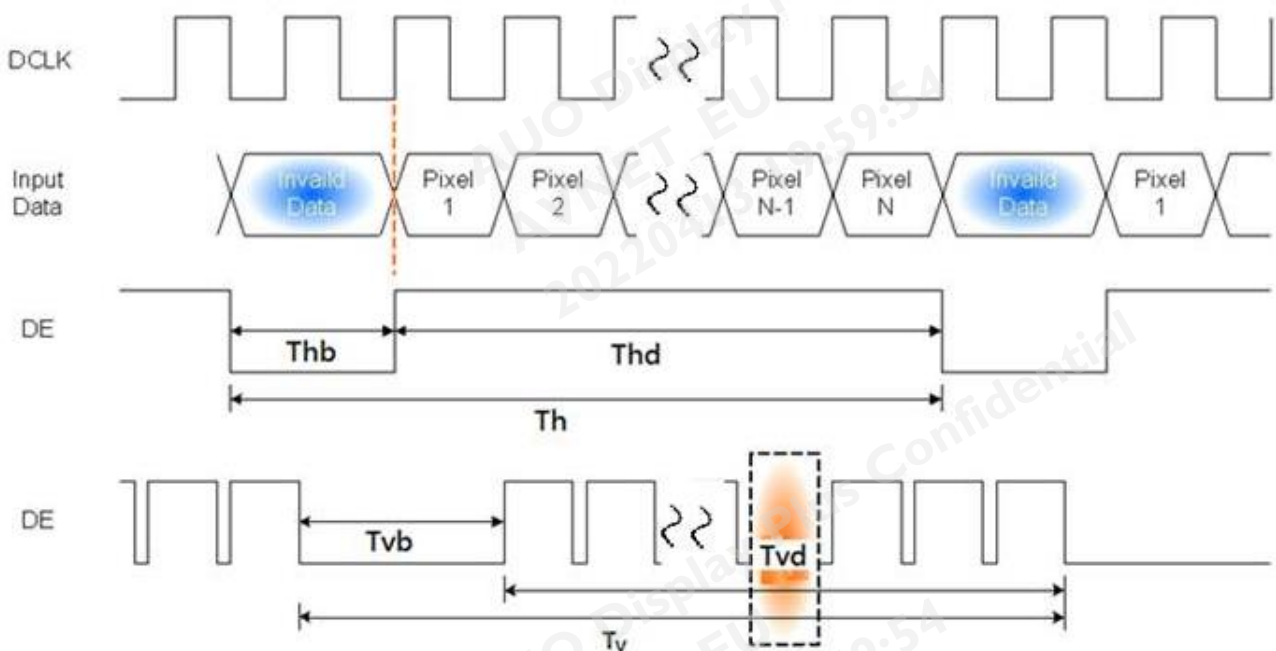

## 6.6 Power ON/OFF Sequence

Power on/off sequence is as follows. Interface signals and LED on/off sequence are also shown in the chart. Signals from any system shall be Hi-Z state or low level when VDD is off.

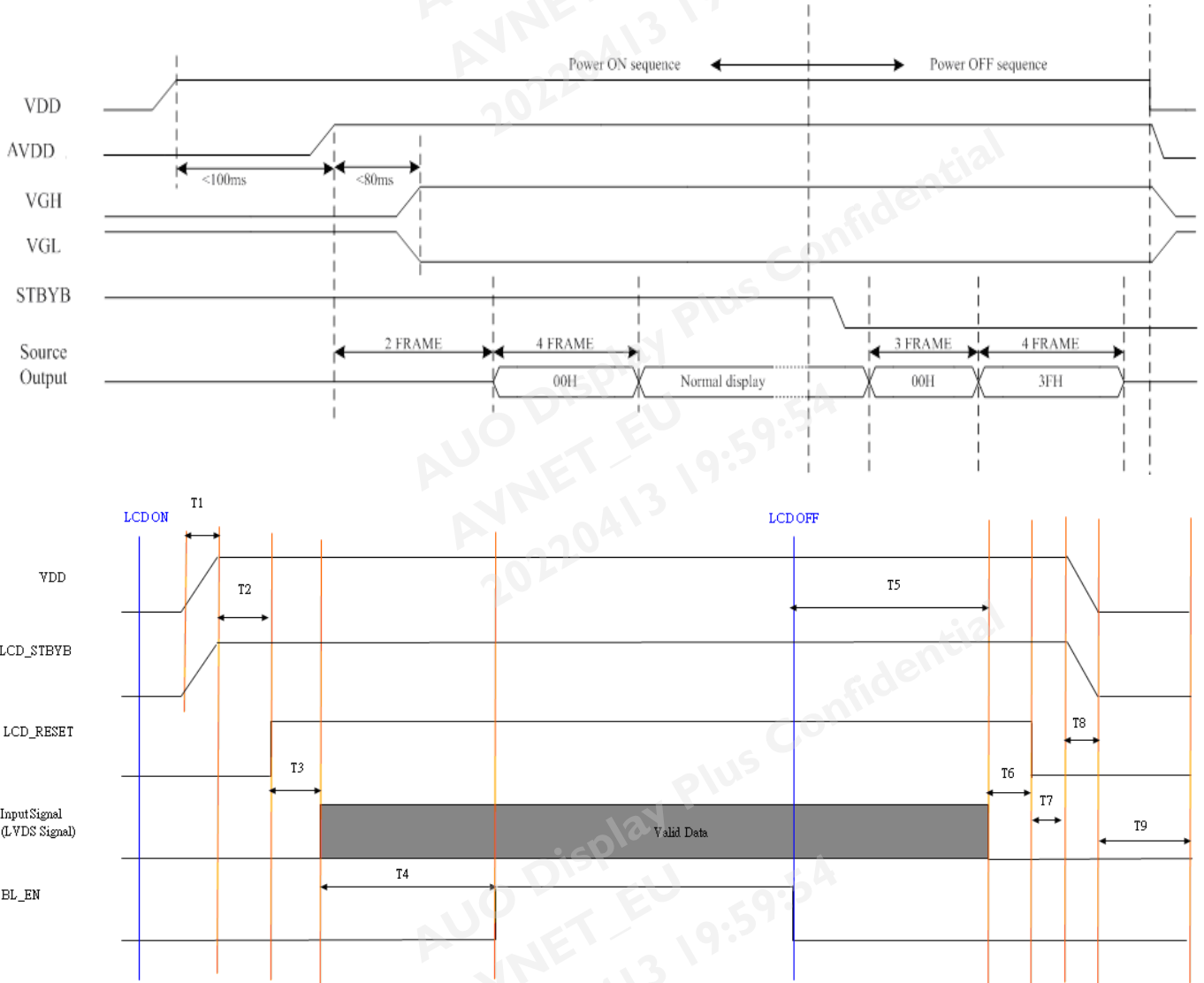

Item	Specification			Unit
	Min	Typ	Max	
T1: VDD Rising Time	0.5	-	10	ms
T2: VDD→RESET High	1	-	-	ms
T3: RESET High →LVDS On	0	-	50	ms
T4: LVDS On→BL On	200	-	-	ms
T5: BL Off→LVDS Off	200	-	-	ms
T6: LVDS Off→RESET Low	0	-	-	ms
T7: RESET Low→VDD off	0	-	-	ms
T8: VDD Falling Time	0	-	10	ms
T9: Discharge Time	500	-	-	ms

Note: The sequence on LCD\_STBYB is the same with VDD.

## 7. Reliability Test Criteria

Item		Specification
High Temperature Storage		Ta = 70°C 240hrs
Low Temperature Storage		Ta = -30°C 240hrs
High Temperature Operation		Ts = 60°C 240hrs
Low Temperature Operation		Ta = -10°C 240hrs
Operate at High Temperature and Humidity		Ta = +40°C, 90%RH 240hrs
Thermal Shock		Ta = -20°C to 60°C, Duration at 30min, 100cycles
Vibration Test	Test method	Non-Operation
	Acceleration	1.5G
	Frequency	10-500Hz Random
	Sweep	30 Minutes each Axis (X,Y,Z)
Shock Test	Test method	Non-Operation
	Acceleration	100G, Half sine wave
	Active time	6ms
	Plus	±X, ±Y, ±Z .3 time for each side
Electro Static Discharge (ESD)		Contact mode : ±8KV class B Air mode : ±15KV class B (All under the condition for R=330, C=150pF)
Carton package vibration test		Condition & Length : Random 1.5G 10~200Hz · X, Y, Z directions, 30min/direction
Carton package drop test		Height 61cm; 1 corner, 3 edges, 6 flats

### Note1:

- According to EN 61000-4-2 , ESD class B: Some performance degradation allowed. Self-recoverable. No data lost, No hardware failures.
- No function failure occurs. Mura shall be ignored after high temperature reliability test.
- The reliability test is performed only to examine the TFT-LCD module capability.

**Note2:** In the standard conditions, there is no function defect occurred. All the cosmetic specification is judged before the reliability stress.

### 8. Mechanical Characteristics

#### 8.1 LCM Outline Dimension

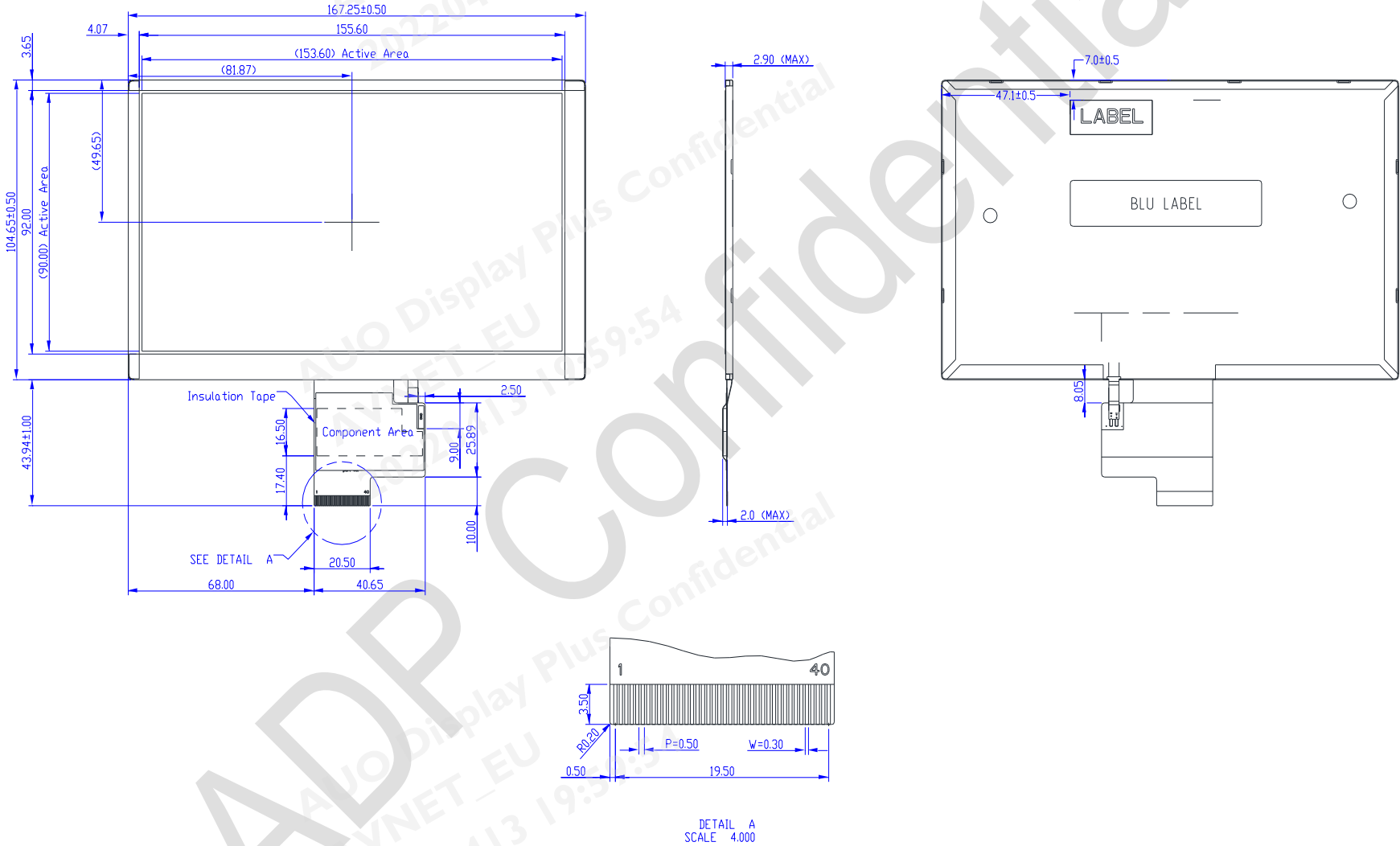

## 9. Label and Packaging

### 9.1 Shipping Label (on the rear side of TFT-LCD display)

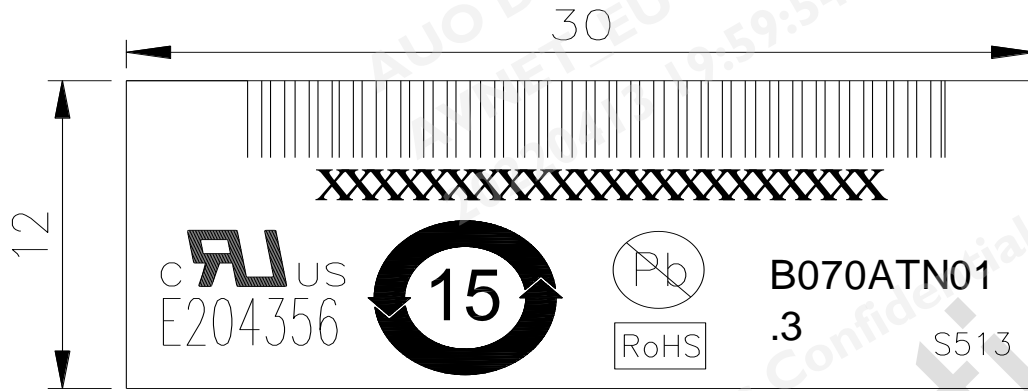

Shipping number description:

No.: 1 2 3 4 5 6 7 8 9 10 11 12 13 14 15 16 17 18 19 20 21 22  
 Ex.: 4 7 2 S 0 6 Z G 7 7 B 5 C T 7 S 0 A C 0 0

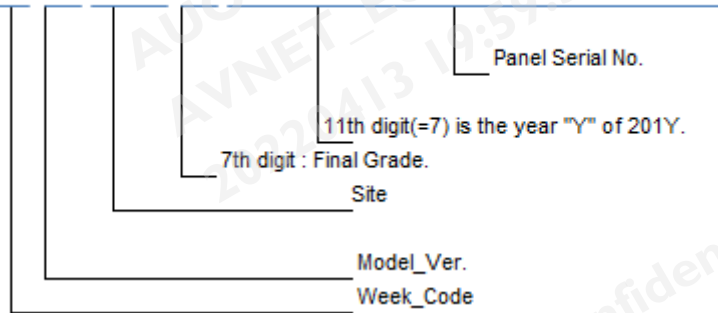

## 9.2 Carton Package

Carton size:  $593 \times 382 \times 225 \text{ mm}^3$

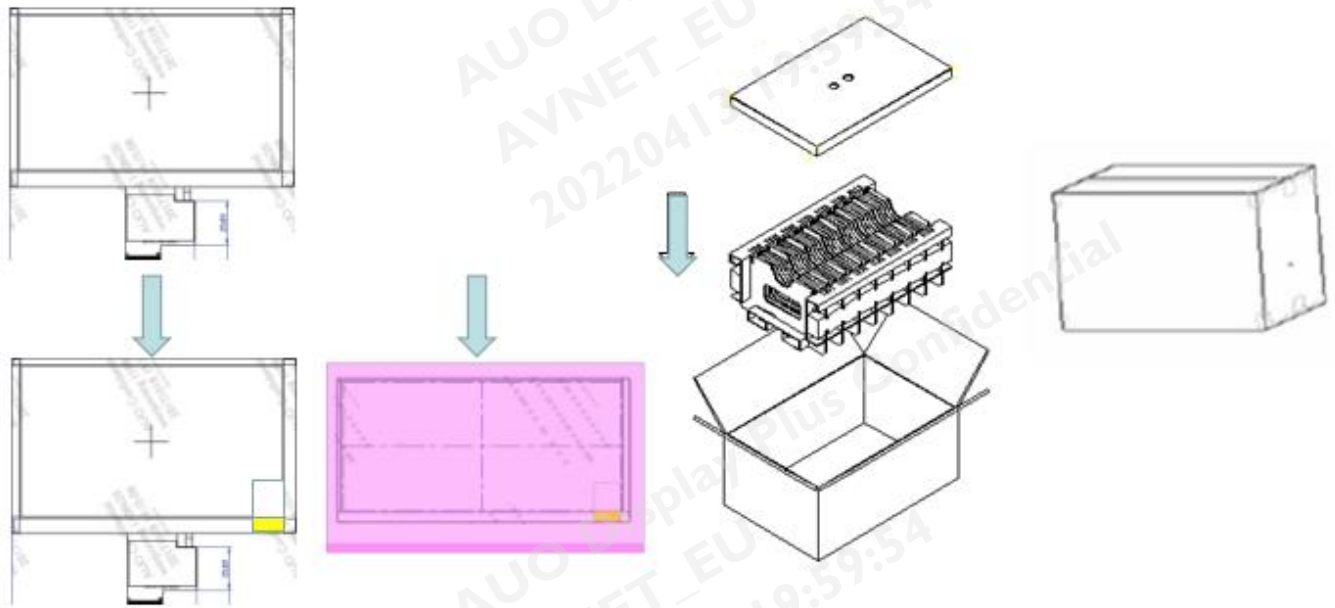

Max capacity : 72 TFT-LCD module per carton

Max weight: 11.0 kg per carton

Outside dimension of carton: 593mm(L)\* 382mm(W)\*225mm(H)

Pallet size : 1200 mm \*800 mm \* 132mm

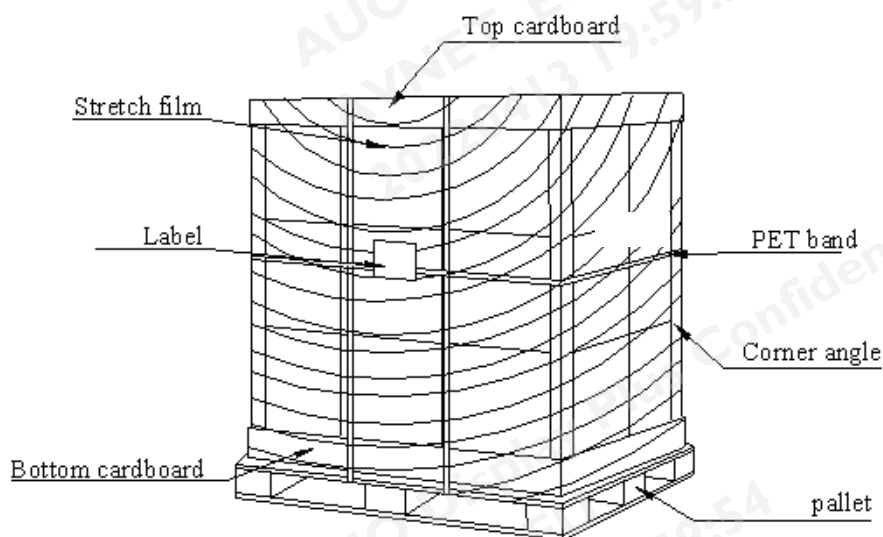



## 10 Safety

### 10.1 Sharp Edge Requirements

There will be no sharp edges or comers on the display assembly that could cause injury.

### 10.2 Materials

#### 10.2.1 Toxicity

There will be no carcinogenic materials used anywhere in the display module. If toxic materials are used, they will be reviewed and approved by the responsible AUO toxicologist.

#### 10.2.2 Flammability

All components including electrical components that do not meet the flammability grade UL94-V1 in the module will complete the flammability rating exception approval process.

The printed circuit board will be made from material rated 94-V1 or better. The actual UL flammability rating will be printed on the printed circuit board.

### 10.3 Capacitors

If any polarized capacitors are used in the display assembly, provisions will be made to keep them from being inserted backwards.

### 10.4 National Test Lab Requirement

The display module will satisfy all requirements for compliance to:

UL 60950-1 second edition

U.S.A. Information Technology Equipment